



FIG. 195

ROLLER HANGER

www.pipingtech.com/fig195

MATERIAL: Cast iron roll, carbon steel yoke, roll rod, and hex nuts.

SERVICE: For suspension of pipe from a single rod where horizontal movement may occur because of expansion or contraction.

HOW TO SIZE: If the roll is to support bare pipe, select the size directly from the nominal pipe size (see table below).

ORDERING: Specify figure number, pipe size, description and finish.

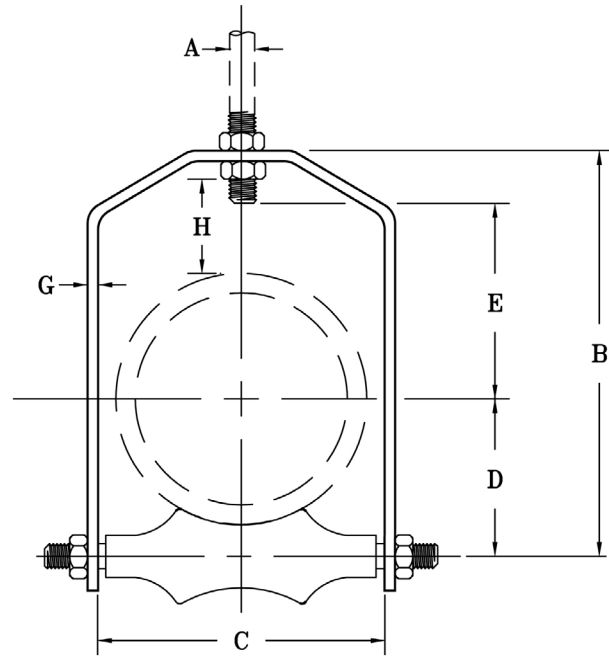

SUPPORT ASSEMBLY COMPONENTS

PIPE SIZE	MAX. O.D. OF COVERING	MAX. RECOM. LOAD (lb.)	APPROX. WEIGHT (lb. per 100)	A	B	C	D	E	F	G	H
2 1/2	3	225	170	1/2	5 3/4	3 1/4	1 15/16	2 7/8	1/2	3/16 x 1	1 11/16
3	3 5/8	310	220	1/2	6 3/8	3 7/8	2 1/4	3 1/8	1/2	1/4 x 1	1 5/8
3 1/2	4 1/8	390	253	1/2	7	4 3/8	2 9/16	3 1/2	1/2	1/4 x 1 1/4	1 11/16
4	4 11/16	475	321	5/8	7 9/16	4 15/16	2 13/16	3 5/8	1/2	1/4 x 1 1/2	1 5/8
5	5 3/4	685	627	5/8	9 1/8	6	3 7/16	4 1/2	5/8	3/8 x 1 3/4	1 15/16
6	6 7/8	780	927	3/4	10 5/16	7 1/8	4	5	3/4	3/8 x 2	1 7/8
8	9	780	1,454	7/8	12 11/16	9 1/4	5 1/8	6 1/8	7/8	3/8 x 2 1/2	2
10	11	965	1,880	7/8	15 1/16	11 1/4	6 3/8	7 1/4	7/8	3/8 x 2 1/2	2 1/16
12	13	1,200	2,774	7/8	17 7/16	13 1/4	7 7/16	8 3/8	1	1/2 x 2 1/2	2 1/4
14	14 1/4	1,200	3,913	1	18 7/8	14 1/2	8 3/8	8 3/4	1 1/8	1/2 x 2 1/2	2
16	16 1/4	1,200	4,905	1	20 13/16	16 1/2	9 3/8	9 11/16	1 1/4	1/2 x 2 1/2	1 15/16
18	18 1/4	1,400	5,780	1 1/8	23 3/4	18 1/2	10 7/16	11 7/16	1 1/4	1/2 x 3	2 11/16
20	20 1/4	1,600	7,594	1 1/4	26	20 1/2	11 5/8	12 1/4	1 3/8	5/8 x 3	2 1/2

SCOMPONENTS02.XLS-07/01/09